

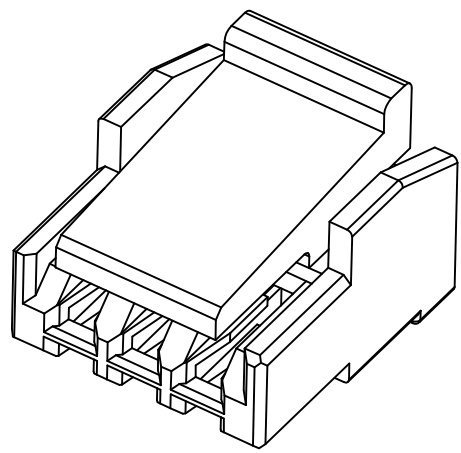

- NOTES:
1. MATERIAL IS HALOGEN FREE PLASTIC,HIGH TEMP, UL 94V-0
 2. SPEC. PLS. REFER TO PS-51451-XXXX-XXX
 3. TERMINAL P/N:51452-TXXX-XXX
 4. PART NUMBER

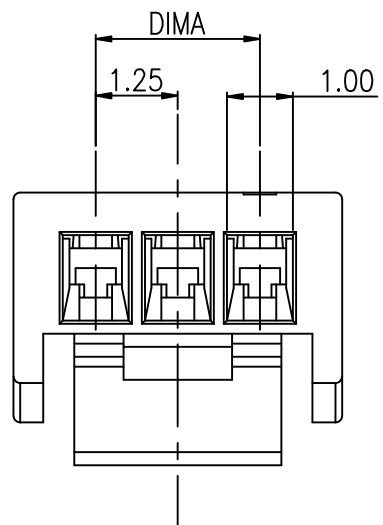

51452-XXXHXXX-XXX

NO OF CKTS ———

Polarization
0: NONE

MATERIAL
H: NYLON 66

XXX	HALOGEN FREE	LOGO
001	HF	ACES

COLOR
0: WHITE
1: BLACK

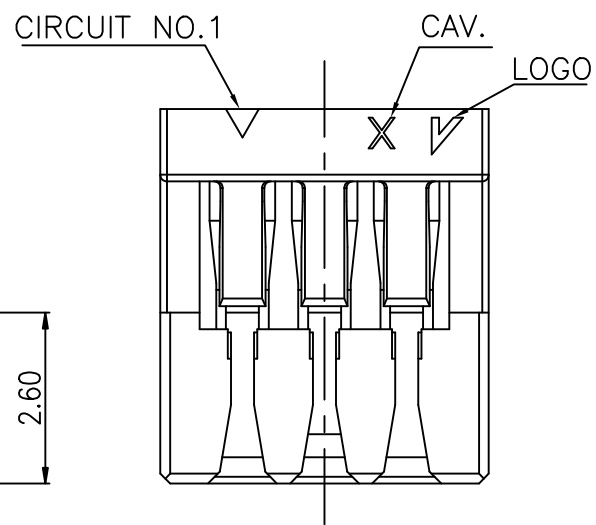
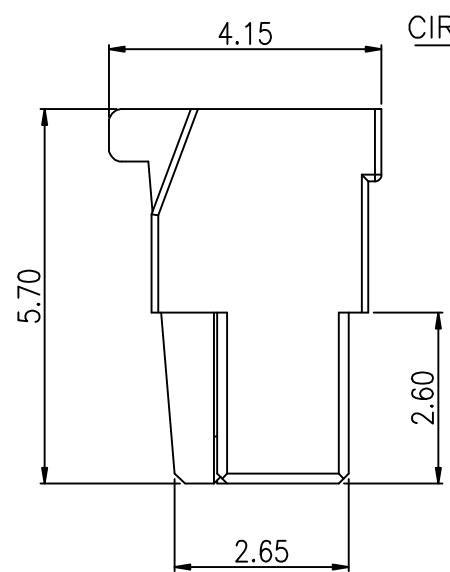
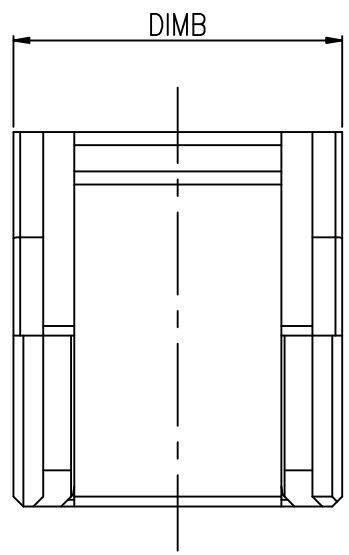

CKT	A	B
002	1.25	3.75
003	2.50	5.00
004	3.75	6.25
005	5.00	7.50
006	6.25	8.75
007	7.50	10.00
008	8.75	11.25
009	10.00	12.50
010	11.25	13.75
011	12.50	15.00
012	13.75	16.25
013	15.00	17.50
014	16.25	18.75
015	17.50	20.00

QUALITY SYMBOLS MAJOR CRITICAL GENERAL TOLERANCES (UNLESS SPECIFIED) X. ±0.5 .X ±0.25 .XX ±0.15 .XXX ±0.1 ANGLES ±2°	DRAWN BY GAOLI CHECKED BY Xu.ZhiYong APPROVED BY Xu.ZhiYong	DATE 23/04/20 DATE 23/04/20 DATE 23/04/20	 ACES ELECTRONICS TITLE 1.25mm WTB CONN HOUSING
	UNITS mm SCALE 1:1	 SHEET NO. 1 OF 1	